



RCP Series Air Compressor Manual



For questions concerning this air compressor,
please call 866-869-3114

TABLE OF CONTENTS

PAGE

1	Safety Guidelines - Definitions Before Using the Air Compressor
2	When Installing or Moving the Compressor Before Each Use
3	Follow Safety Precautions for Electrical Connection Plan Ahead to Protect Your Eyes, Hands, Face & Ears When Operating
4	Spraying Precautions Perform These Maintenance Operations
5	Typical Compressor Installation Glossary
6-9	Wiring
10	Starting the Compressor
11-12	QP Compressor
13-14	Troubleshooting
15	Pump and Tank Specs
16	Tank Warning
17	Parts Reference
18	Single Stage and Contractor
19	Two Stage (RCP)
20	Gas Drive (RCP and RCP-C) and Duplex (RCP)
21	QP
22	RCP-C Electric Two Stage and Duplex
23-24	PAT24 and PAT38
25	T29S
26	B5900
27	T39
28-29	C1
30-31	C2
Back	Warranty Statement

SAFETY GUIDELINES - DEFINITIONS

Safety is a combination of common sense, staying alert and knowing how your compressor works. Read this manual to understand this compressor.



DANGER

means if safety information is not followed someone **will** be seriously injured or killed



WARNING

means if safety information is not followed someone **could** be seriously injured or killed



CAUTION

means if safety information is not followed someone **may** be seriously injured or killed

IMPORTANT SAFETY INSTRUCTIONS

Save these instructions

Improper operation or maintenance of this product could result in serious injury and property damage. Read and understand all warnings and operation instructions before using this compressor.

Before using the air compressor

Things you should know

Air compressors are utilized in a variety of air system applications. Because air compressors and other components (hoses, connectors, air tools, spray guns, etc.) make up a high pressure pumping system, the following safety precautions should be observed at all times.

Only persons familiar with these rules of safe operation should use the air compressor.

1. Read the instruction manual carefully before attempting to assemble, disassemble or operate your system. Be thoroughly familiar with the controls and the proper use of the equipment.
2. Review and understand all safety instructions and operating procedures in this manual.
3. Review the maintenance methods for this compressor (See "Maintaining Your Compressor" section).

Inspect your work area

1. Keep work area clean.
2. Cluttered areas and benches invite accidents. Floors must not be slippery from wax or dust.

Inspect your compressor

1. To reduce the risk of injury from accidental starting, turn switch off and disconnect the power before checking it.
2. If any part is missing, bent or broken in any way, or any electrical part does not work properly, keep the compressor off and disconnected.
3. Check hoses for weak or worn condition before each use, making certain all connections are secure. Do Not use if defect is found.



WARNING

Do not operate compressor if damaged during shipping, handling or use. Damage may result in bursting and cause injury or property damage.



DANGER

This compressor is Not designed for and should not be used in breathing air applications.

When installing or moving the compressor

WARNING

This compressor is extremely top heavy. The compressor must be bolted to the floor with vibration pads before operating to prevent equipment damage, injury or death. **Do Not** tighten bolts completely as this may cause stress to the tank welds. **Chart 1a.**

To reduce the risk of a dangerous environment

1. Keep work area well lit.
2. Operate compressor in a well-ventilated area free from flammable liquids and vapors.
3. Operate compressor in a ventilated area so that compressor may be properly cooled and the surrounding air temperature will not be more than 100°F.
4. Never use a compressor in a wet environment.
5. Protect material lines and air lines from damage or puncture. Keep hose and wires away from sharp objects, chemical spills, oil, solvents and wet floors.

WARNING

Do Not secure compressor with toggle bolts into drywall. Drywall sheeting or plaster will not support the weight of the compressor.

Always Shut Off Gas Valve before moving Gas Drive Compressors

6. A minimum clearance of 18 inches between the compressor and a wall is required because objects could obstruct airflow.
7. The compressor should be located where it can be directly wired to a circuit breaker. The compressor should be wired by a qualified electrician.
8. Never store flammable liquids or gases in the vicinity of an operating compressor.
9. **Do Not** locate the compressor air inlet near steam, paint spray, sandblasting areas or any other source of contamination. The debris could damage the motor and pump.

WARNING

Never use plastic (PVC) pipe for compressed air. Serious injury or death could result.

CAUTION

Never use the shipping skid for mounting the compressor.

NOTICE

Electric Compressors are not suitable for outdoor installation.

NOTICE

Gasoline Compressors must be operated outdoors, sheltered from the weather.

WARNING

Never install a shut off valve between the compressor pump and tank. Personal injury and/or equipment damage could occur.

Before each use

Inspect your work area

1. Keep work area clean. Cluttered areas and benches invite accidents.
2. The floor must not be slippery from wax or dust.

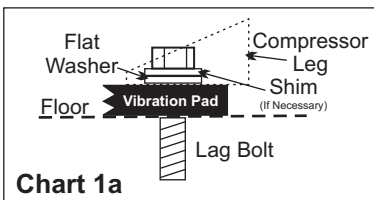

Chart 1a

Inspect your compressor

1. To reduce the risk of injury from accidental starting, turn the switch off and disconnect power.
2. If any part is missing, bent or broken in any way, or any electrical part does not work properly, keep the compressor off and disconnect power. **Do Not** use if defect is found.
3. Check hoses for weak or worn condition before each use, making certain all connections are secure. **Do Not** use if a defect is found.

Follow the safety precautions for electrical connections

1. Follow all local electrical and safety codes, as well as the National Electric Code (NEC) and the Occupational Safety and Health Act (OSHA).
2. Wiring and fuses should follow electrical codes, current capacity and be properly grounded.
3. Protect wires from contact with sharp objects.



CAUTION

All electrical connections should be made by a qualified electrician.

Plan ahead to protect your eyes, hands, face and ears

Dress for safety

1. Wear safety glasses (meeting ANSI Z87.1 or in Canada CSA Z94.3-99) and use hearing protection when operating the unit. Everyday glasses are not safety glasses.
2. Wear shoes to prevent shock hazards.
3. Tie back long hair.



WARNING

Be careful when touching the exterior of compressor, pump, motor and air lines; they may become hot enough to cause injury.



WARNING

Never operate the compressor without a beltguard. The compressor can start automatically without warning. Personal injury or property damage could occur from contact with moving parts.



CAUTION

The compressor may be hot even if the unit is stopped.



WARNING

Use of a mask or respirator per chemical manufacturers' instructions may be necessary if there is a chance of inhaling toxic fumes. Read mask and respirator instructions carefully. Consult a safety expert if you are not sure about the use of certain masks or respirators.

Pay attention to your hands



WARNING

Keep fingers away from running compressor. Fast moving and hot parts may cause injury and/or burns.

When operating

1. Do not exceed the pressure rating of any component of the system.
2. Release pressure within the system slowly to prevent flying dust and debris.
3. If the equipment starts to abnormally vibrate, STOP the compressor immediately and check for the cause.



WARNING

Never change the safety valve or pressure switch settings. Keep safety valve free from paint and other accumulations. See compressor specification decal for maximum operating pressure. Do not operate with the pressure switch set higher than the maximum operating pressure.

Spraying precautions



WARNING

Never point a spray gun at yourself or any other person or animal. Accidental discharge may result in serious injury.

Reduce the risk of dangerous environment



WARNING

Extreme caution should be taken when spraying flammable liquids as the spark from a motor or pressure switch may cause a fire or explosion. Ample ventilation must be provided.



WARNING

Spray in a well ventilated area to keep fumes from collecting and causing serious injury and fire hazards.

1. **Do Not** spray in the vicinity of open flames or other places where a spark can cause ignition. **Do Not** smoke when spraying paint, insecticides, or other flammable substances.

Be informed about the materials you use

1. When spraying with solvents or toxic chemicals, follow the instructions provided by the chemical manufacturer. Consult a safety expert if unsure about the use of masks or respirators.
2. If the material you intend to spray contains trichloroethane and methylene chloride, do not use accessories that contain aluminum or galvanized materials, as these chemicals can react with galvanized components causing corrosion and weakening equipment. Use stainless steel accessories.

Perform these maintenance operations

1. Do regular maintenance; keep all nuts, bolts, and screws tight, to be sure equipment is in safe working condition.
2. Inspect tank yearly for rust, pin holes or any other imperfections that could cause it to become unsafe.



WARNING

NEVER attempt to repair or modify a tank! Welding, drilling or any other modification will weaken the tank resulting in damage from rupture or explosion. Always replace worn, cracked or damaged tanks.

3. Clean electrical equipment with an approved cleaning agent, such as a dry, non-flammable cleaning solvent.

4. Drain tanks of moisture after each day's use. If unit will not be used for awhile, it is best to leave the drain cock open until such time as it is to be used. This will allow moisture to completely drain out and help prevent corrosion of inside of tank.
5. Always disconnect from power source before working on or near a motor, or its connected load. If power disconnect point is out-of-sight, secure it in the "OFF" position and tag it to prevent unexpected application of power.



WARNING

Disconnect power and depressurize system before servicing air compressor. Slightly open drain cock after shutting off compressor.

Daily

Check oil level at sight glass. Oil level should be 1/2 to slightly higher in the oil sight glass.

Drain moisture from tank.

Verify the pressure switch unloader is working by listening for a brief hissing sound when the compressor shuts off.

Visually check the compressor for loose parts, excessive noise or vibration. Tighten any necessary part.

Monthly

(Make sure the main power is off.) Check the belts for tension. Belts should not move up and down when the compressor runs and when stopped, should not have more than 1/2 in of play when depressed. Be careful not to over tighten belts during adjustment.

Remove and check air filter, replace if necessary.

Change oil every 3 months or 300 hours. A compressor grade 30 wt non-detergent oil should be used. *40 wt non-detergent for single stage.*

TYPICAL COMPRESSOR INSTALLATION

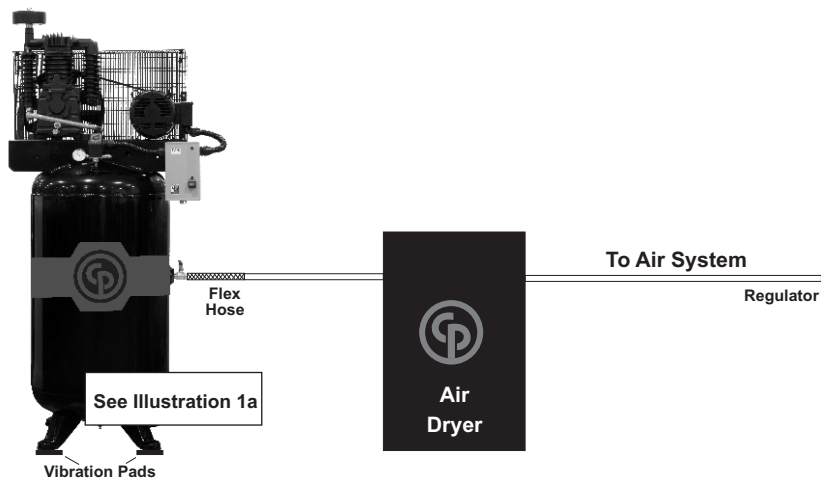

GLOSSARY OF TERMS

Air Filter

Porous element contained within a metal or plastic housing attached to the compressor cylinder head which removes impurity from the intake air of the compressor.

Air Tank

Cylindrical component which contains the compressed air.

Check Valve

Device which prevents compressed air from flowing back from the air tank to the compressor pump.

Electric Motor

Device which provides the rotational force necessary to operate the compressor pump.

Pressure Gauge

Device which shows the tank or regulated pressure of the compressed air.

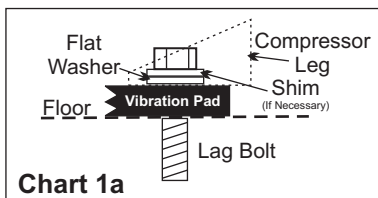

Chart 1a

Pressure Switch

Device which automatically controls the on/off cycling of the compressor. It stops the compressor when the cut-off pressure in the tank is reached and starts the compressor when the air pressure drops below the cut-in pressure.

PSI (Pounds per Square Inch)

Measurement of the pressure exerted by the force of air. The actual psi is measured by a pressure gauge on the compressor.

Pump

Device which produces the compressed air with a reciprocating piston contained within a cylinder.

Safety Valve

Device which prevents air pressure in the air tank from rising over a predetermined limit.

Thermal Overload Switch

Device, integrated into the electric motor winding, which automatically "shuts off" the compressor if the temperature of the electric motor exceeds a predetermined limit.

WIRING

⚠ WARNING

ALL ELECTRICAL WIRING SHOULD BE DONE BY A QUALIFIED ELECTRICIAN

General Information

Adequate wiring and motor protection should be provided for all stationary compressors. Wiring used for other machinery should not be used. A qualified electrician familiar with local electrical codes in your area should be used. Size supply wiring per NEC (National Electric Code) requirements.

⚠ WARNING

To reduce the risk of electrical hazards, fire hazards or damage to the compressor, use proper circuit protection. Your compressor is wired at the factory for operation using the voltage shown. Connect the compressor to a power source with the correct breaker size.

⚠ CAUTION

Overheating, short circuiting and fire damage will result from inadequate wiring.

⚠ WARNING

Electrical connections must be properly grounded. Ground connections should be connected at the grounding screw. 

DO NOT MAKE CONNECTIONS AT THE PRESSURE SWITCH (Units with Magnetic Starters)

Single Phase

Incoming power should be connected to L1 and L2 at the Top of the Magnetic Starter.

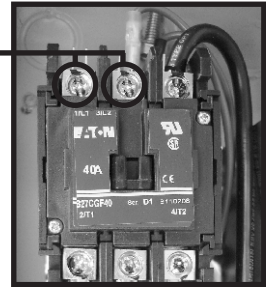

Three Phase

Incoming power should be connected to L1, L2 & L3 at the Top of the Magnetic Starter.

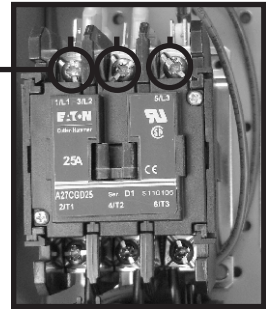

Overload Adjustment

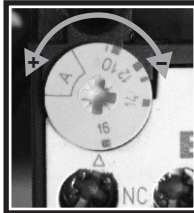

Duplex Wiring (Inside Controller on the Bottom)



Single Phase

Three Phase

For Models Without Magnetic Starter

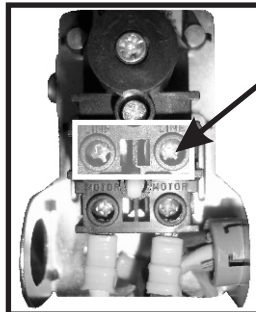

Incoming power should be connected to the posts marked (LINE)



Do Not Make Connections On Prewired Posts Marked (MOTOR)!



Electrical connections must be properly grounded. Ground connections should be connected at a grounding screw. 

WIRING

1 PHASE START/STOP CONTROL WIRING SCHEMATIC

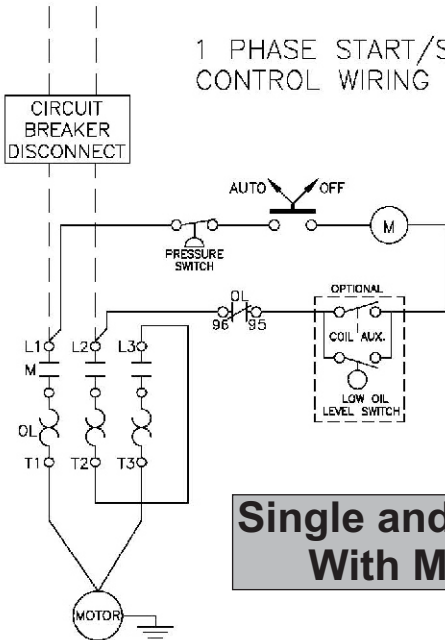

Single and Three Phase With Mag Starter

3 PHASE START/STOP CONTROL WIRING SCHEMATIC

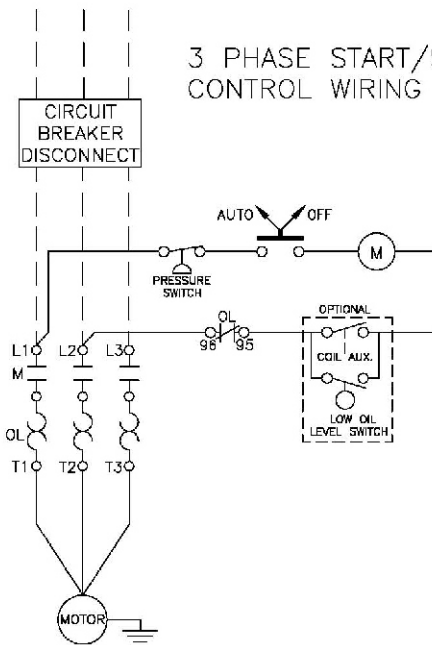

--- Customer supplied

WIRING

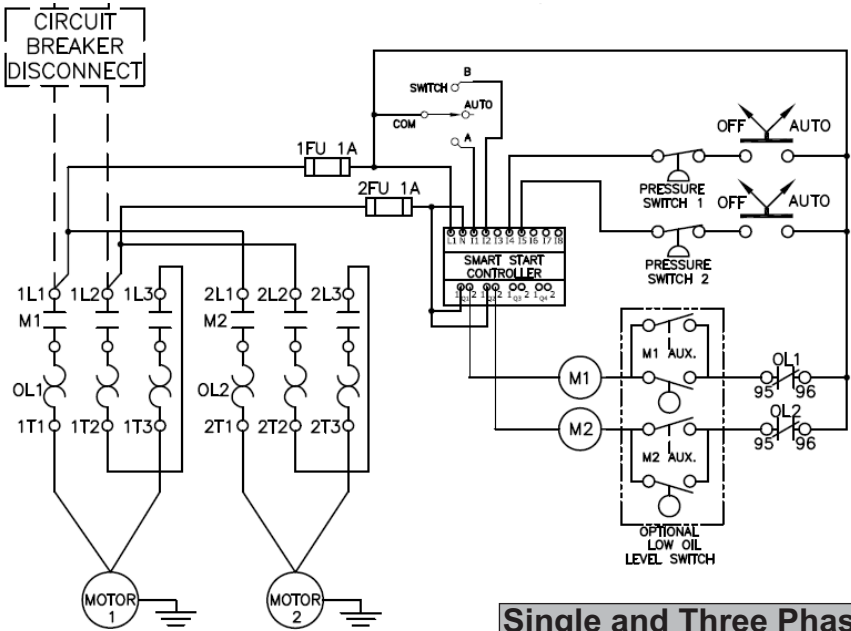

Single and Three Phase Duplex

DUPLEX 3 PHASE START/STOP CONTROL WIRING SCHEMATIC

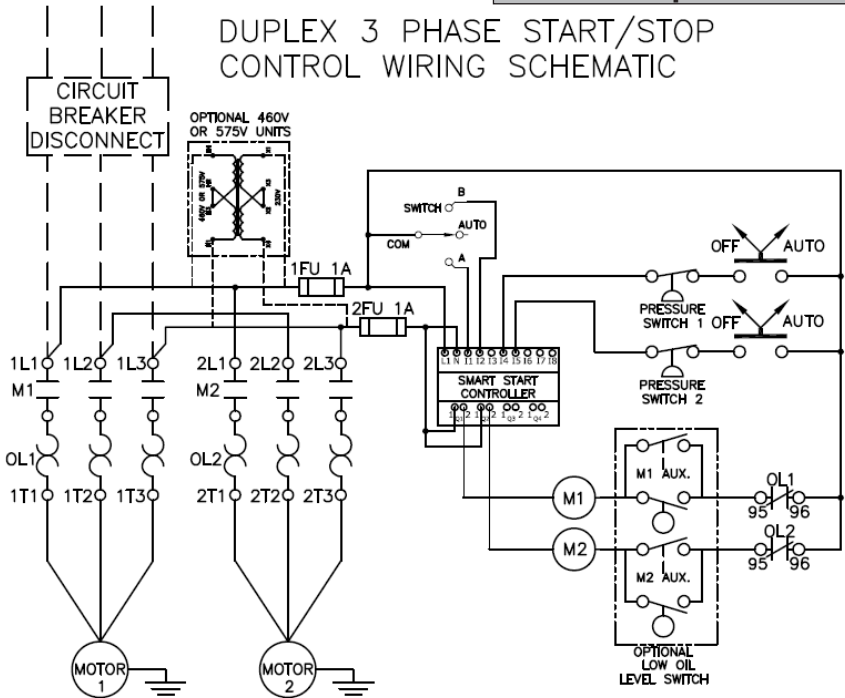

— — Customer supplied

WIRING

QP 1 PHASE START/STOP CONTROL WIRING SCHEMATIC

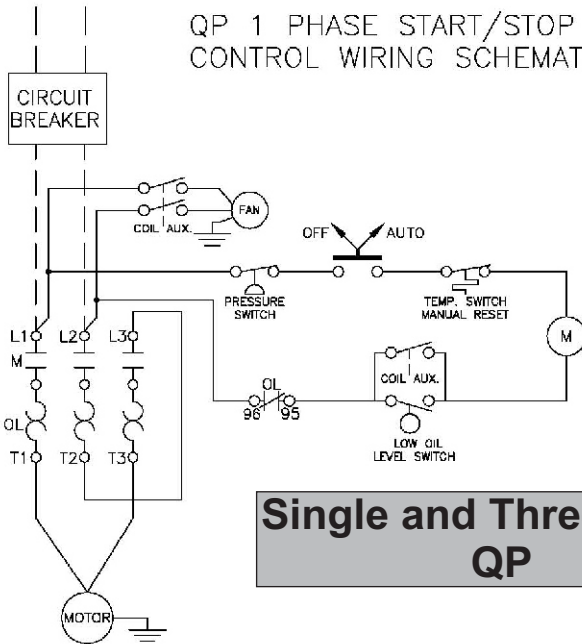

Single and Three Phase QP

QP 3 PHASE START/STOP CONTROL WIRING SCHEMATIC

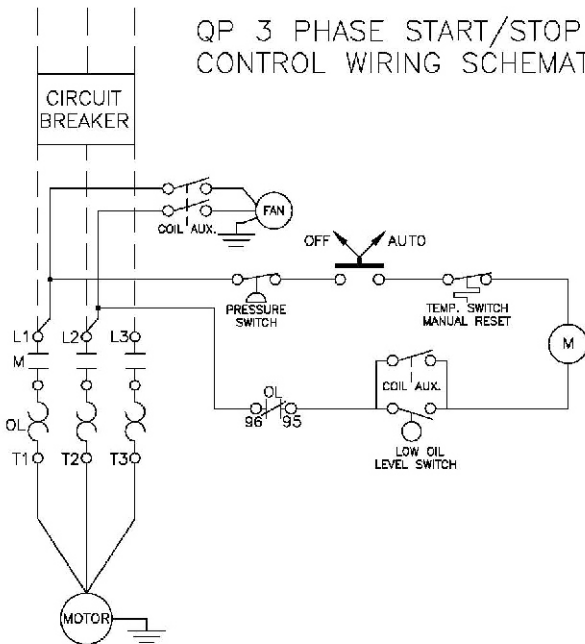

— — Customer supplied

STARTING THE COMPRESSOR

Prior to actually running the compressor, check the following items:

Crankcase oil - Make sure the sight glass shows $\frac{1}{2}$ full or slightly above.

Make sure all rags, tools, oil, etc. are away from the unit.

Open the air system to free it of any pressure.

Switch the compressor on for a few revolutions to make sure the rotation is correct. Correct rotation is clockwise when facing the sight glass on the pump.

Operate the compressor for a few minutes unloaded (air system open) then allow the compressor to pump up. Make sure the electrical pressure switch properly switches off the compressor according to the setting desired. 175 for Two Stage. (135 psi - Single Stage or 165 psi - RCP-561VNS)



CAUTION

Make sure the pressure in the tank does not exceed its rating. Single Stage units - 135 psi
Two Stage units at a maximum of 175 psi. (165 for Model RCP-561VNS)
If the pressure gauge indicates a pressure that is higher than these maximum pressures, shut off compressor immediately and call your distributor.

(Duplex Models)

Alternating Running Procedure

Initial power to the controller takes about 5 seconds to power up and run
Motor A will start and then Motor B after a 10 second delay
Both motors will run until unit reaches cutoff pressure (175 psi)
Each time the unit starts after initial start, the "Lead" motor will alternate
If the unit runs for more than 5 minutes, the second Motor will come on and run until the unit reaches cutoff pressure
The second motor will also come on if the air demand is higher than one pump/motor can produce and the pressure drops to around 135 psi (10 sec. delay)

A or B Running Procedure

By selecting A or B on the switch, either Pump/Motor A or Pump/Motor B will operate independently, as a simplex compressor.

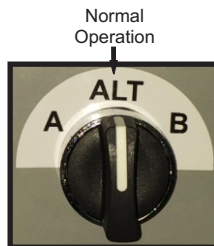

(Gas Drive Models)

PLEASE REFER TO YOUR ENGINE OPERATION MANUAL FOR PROPER STARTING INSTRUCTIONS.

GASOLINE DRIVEN COMPRESSORS ARE EQUIPPED WITH A COLD START VALVE FOR LOADLESS STARTS.

NOTE: IN SOME INSTANCES, IT STILL MAY BE NECESSARY LIFT THE TOGGLE ON THE UNLOADER/PILOT VALVE TO RELIEVE THE HEAD PRESSURE. See Page 11

Battery Connection Instructions for Electric Start Engines

Note: Make sure to follow instructions carefully to avoid a short and possible damage to the starter solenoid and/or battery.

1. Connect the positive (+) terminal on the battery to the starter solenoid.
2. Connect the negative (-) terminal on the battery to an engine mounting bolt or other acceptable ground connection.

Always connect the positive(+) battery cable to the starter solenoid before connecting the negative(-) battery cable.

NUMBER 2 WIRE OR LARGER IS REQUIRED

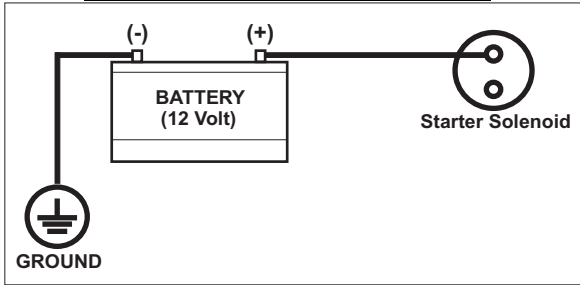

Cold Start Procedure (Gasoline Engine Units)

Warning: Do Not Operate Gasoline Engine Units in an Enclosed Area

- Release any remaining tank pressure by slowly opening the manual drain valve.
- Turn on the engine gasoline supply.
- Put the choke in the “On” position
- Close the service valve and put Unloader lever in the “unload” (A) position for Briggs and Stratton and Honda engine driven models, or the “load” (B) position for Kohler engine models.
- Start the engine, release the choke, and allow the engine to warm up for two to three minutes.
- Return the unloader lever to the “load” (B) position on Briggs and Stratton and Honda driven models.

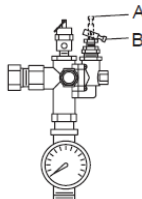

Note: Turn the gasoline supply off when the compressor is not being used

QP Compressors

You have purchased a state of the art Chicago Pneumatic QP compressor. The QP comes equipped with sound attenuating enclosure. For maintenance, the canopy and side foam pieces will need to be removed.

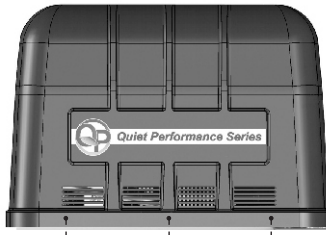

To remove the canopy, simply remove the 6 fasteners and lift the canopy straight up and off.

QP and Premium Compressors

CP Premium and QP models come equipped with low oil level switches and automatic tank drains. The QP models also include protection against over-heating.

Low Oil Level Switch

The function of the low oil level switch is to keep the air compressor from starting if the oil level drops beyond a certain point.

For compressors outfitted with the low oil level switch, the oil should be in the top 1/3 of the oil sight glass.

When changing or adding oil, it is important to remove the Oil Vent Plug to allow for the oil to flow completely into the switch.

(Please Note: If overfilled, oil will flow out of the oil vent hole)

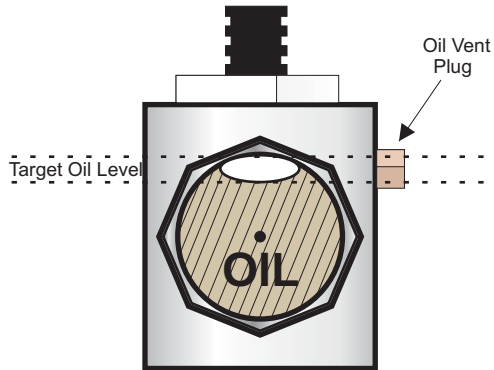

Thermal Protection - QP Models

If the cooling fan were to fail or internal temperature were to reach 180°F the QP models are outfitted with a thermal fuse.

When tripped, the fuse can be reset. The canopy will need to be removed to reset the thermal fuse.



Press to
Reset

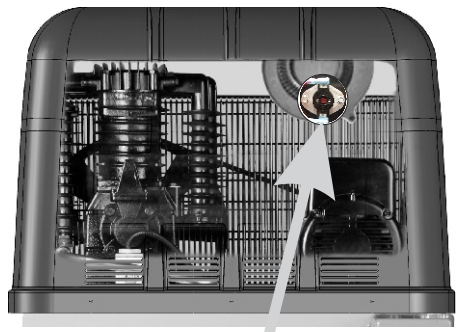

Location of Fuse
(Inside Canopy
Behind Fan)

TROUBLESHOOTING GUIDE

<p>Low discharge pressure</p>	<ol style="list-style-type: none"> 1. Compressor too small for application 2. Air leaks 3. Restricted intake air 4. Blown gasket(s) 5. Broken or misaligned valves 	<ol style="list-style-type: none"> 1. Reduce air demand or use a compressor with more air capacity. 2. Listen for air leaks. Apply a soap solution to all fittings and connections. Bubbles will form at points of leakage. Tighten or replace fittings or connections. 3. Clean or replace air filter. 4. Replace necessary gaskets. 5. Remove head and inspect for broken or misaligned valves. Replace valves, if necessary. <p>⚠ CAUTION Install a new head gasket each time head is removed</p>
<p>Excessive noise "knocking"</p>	<ol style="list-style-type: none"> 1. Loose drive pulley or flywheel 2. Low on oil 3. Worn connecting rod or connecting rod bearing 4. Noisy check valve 	<ol style="list-style-type: none"> 1. Tighten drive pulley or flywheel bolt. 2. Check for proper oil level. Low or dirty oil may cause bearing damage. 3. Replace connecting rod and/or connecting rod bearings. 4. Replace check valve. <p>⚠ DANGER Do not remove check valve with air pressure in tank</p>
<p>Excessive oil carryover</p>	<ol style="list-style-type: none"> 1. Worn piston rings 2. Restricted intake air 3. Too much oil in compressor 4. Incorrect oil viscosity 	<ol style="list-style-type: none"> 1. Replace with new piston rings. 2. Clean or replace air filter. 3. Drain oil to proper oil level. 4. Use a quality non-detergent 30 or 40wt oil specified for each model (Page 4).
<p>Water in tank and/or discharge line</p>	<ol style="list-style-type: none"> 1. Normal. Amount of water will increase as humidity in the air increases. 	<ol style="list-style-type: none"> 1. Drain tank at least once per day. 2. Add an inline filter to reduce moisture in the air line.
<p>Will not run or motor hums</p>	<ol style="list-style-type: none"> 1. Low voltage 2. Malfunctioning pressure switch 3. Malfunctioning check valve 	<ol style="list-style-type: none"> 1. Check voltage with volt meter across both legs of incoming power. Check reset button on motor. 2. Repair or replace pressure switch. 3. Replace check valve or pressure switch. <p>⚠ DANGER Do not remove check valve with air pressure in tank</p>
<p>Breaker or reset repeatedly trips</p>	<ol style="list-style-type: none"> 1. Incorrect breaker size 2. Low voltage 3. Malfunctioning motor 4. Loose electrical connections 5. Malfunctioning pressure switch 6. Malfunctioning check valve 	<ol style="list-style-type: none"> 1. Make sure the breaker is sized properly. See page 6 in this manual. 2. Check voltage with volt meter across both legs of incoming power. 3. Replace motor. 4. Check all electrical connections. 5. Adjust or replace pressure switch. 6. Replace check valve. <p>⚠ DANGER Do not remove check valve with air pressure in tank</p>
<p>Tank does not hold pressure when not running and shut off valve is closed</p>	<ol style="list-style-type: none"> 1. Malfunctioning check valve 2. Loose fittings or connections 3. Crack or pin hole in tank 	<ol style="list-style-type: none"> 1. Replace check valve. <p>⚠ DANGER Do not remove check valve with air pressure in tank</p> <ol style="list-style-type: none"> 2. Tighten or replace fittings or connections. 3. Replace tank. Do not attempt to repair tank.

TROUBLESHOOTING GUIDE (Continued)

Pressure switch unloader constantly leaking air	1. Malfunctioning check valve	1. Replace check valve if unloader bleeds constantly. ⚠ DANGER Do not remove check valve with air pressure in tank
Pressure switch not unloading	1. Malfunctioning pressure switch	1. Replace pressure switch if it does not release air pressure briefly when unit shuts off. ⚠ DANGER Do not remove pressure switch with air pressure in tank
Excessive vibration	1. Improper installation 2. Loose belts 3. Misaligned flywheel or drive pulley	1. Make sure unit is mounted on a level surface with vibration pads. 2. Replace belts. Align and tighten properly. 3. Align flywheel and drive pulley.
Overheating	1. Compressor too small for application 2. Cooling surfaces dirty 3. Improper cooling	1. Reduce air demand or use a compressor with more air capacity. 2. Clean all cooling surfaces of dirt and dust. 3. Install compressor in an area with adequate cool dry air.

Pump Specifications

Pump Model	Pump P/N	Cyl. No.	Stages
PAT24	4116091136	2	1
PAT38	4116091337	2	1
T39	4116090019	2	2
T29S	4116090112	2	2
B5900	4116090137	2	2
C1	1312202800	2	2
C2	1312202700	4	2

Pump Model	Cyl. Diam. In. (mm)		Stroke in. (mm)	Max rpm	Oil Cap. Qt. (L)	Displacement @ max RPM	
	1st Stg	2nd Stg				CFM	L/M
PAT24	2.48 (63)	N/A	1.50 (38)	1400	.56 (0.53)	11.71	331.59
PAT38	2.48 (63)	N/A	2.36 (60)	1400	.91 (.86)	18.49	523.58
T39	4.13 (105)	2.05 (52)	2.95 (60)	1400	1.09 (1.03)	32.02	906.63
T29S	3.74 (85)	1.97 (45)	1.97 (45)	1400	1.44 (1.36)	17.53	496.50
B5900	4.13 (105)	2.16 (55)	2.16 (55)	1400	1.72 (1.63)	23.44	663.84
C1	4.13 (105)	2.16 (55)	3.5 (89)	1000	1.31 (1.24)	27.13	768.33
C2	4.13 (105)	2.16 (55)	3.5 (89)	900	1.5 (1.42)	48.84	1382.99

Pump Model	Bolt Torque Ft.-Lbs. (NM)				
	Conrod	Head	Cylinder	Bearing Housing	Flywheel
PAT24	N/A	18-20 (24-27)	18-20 (24-27)	5-7 (7-10)	18-20 (24-27)
PAT38	N/A	18-20 (24-27)	18-20 (24-27)	5-7 (7-10)	18-20 (24-27)
T39	20-22 (27-30)	30-33 (40-45)	16-19 (22-26)	19-22 (26-30)	34-37 (46-50)
T29S	18-20 (24-27)	18-20 (24-27)	18-20 (24-27)	5-7 (7-10)	18-20 (24-27)
B5900	18-20 (24-27)	18-20 (24-27)	18-20 (24-27)	5-7 (7-10)	18-20 (24-27)
C1	34-37 (46-50)	34-37 (46-50)	19-27 (26-37)	14-19 (19-26)	47-57 (64-77)
C2	34-37 (46-50)	34-37 (46-50)	19-27 (26-37)	14-19 (19-26)	47-57 (64-77)

Tank Specifications

Volume		Max Pressure		Discharge Conn.
Gal.	Liter	PSI	Bar	NPT
20H	76	150	10.345	1/4"
26V	99	150	10.345	1/4"
60V	228	170	11.724	1/2'
2X4	2X15.2	200	13.793	3/8"
2X5	2X19	200	13.793	3/8"
80H	228	200	13.793	3/4"
80V	300	200	13.793	3/4"
30H	114	200	13.793	3/4"
120V	456	200	13.793	3/4"
120H	456	200	13.793	3/4"
120D	456	200	13.793	3/4"
200D	760	200	13.793	3/4"

Tank Warning



WARNING

Oil and moisture residue must be drained from the air receiver daily or after each use. Accumulations of oil residue in the receiver can be ignited by embers of carbon created by the heat of compression - causing an explosion, damage to property and injury to personnel



WARNING

Do not open a manual tank drain valve on any air tank containing more than 30 PSIG of air pressure!



WARNING

Never attempt to relieve an air tank by removing a pipe plug or any other system component!

Manually Draining An Air Tank:

- Step 1)** Disconnect & lockout the compressor from the power source (electric models) or disconnect the spark plug wire from the spark plug (gas engine models).
- Step 2)** Tank(s) subjected to freezing temperatures may contain ice. Store the compressor in a heated area before attempting to drain moisture from the tank(s). Reduce the air pressure in the tank to 30 PSIG by pulling the pressure relief valve ring (refer to **Fig. 3-4, Checking Pressure Relief Valves & Relieving System Pressure**).
- Step 3)** Slowly open the drain valve and allow the moisture and air mixture to drain from the tank.
- Step 4)** Once the moisture has been completely drained, close the drain valve.

Air Tank Inspection

Tank Capacity	Horizontal or Vertical	Minimum Allowable Wall		Visually Inspect	Hydrostatically Inspect
		HEAD	SHELL		
8 Gal.	Horizontal	0.096	0.094	Yearly	10 Years
8 Gal.	Twin Horz.	0.098	0.098	Yearly	10 Years
10 Gal.	Twin Horz.	0.118	0.118	Yearly	10 Years
20 Gal.	Horizontal	0.094	0.094	Yearly	10 Years
26 Gal.	Vertical	0.094	0.094	Yearly	10 Years
30 Gal.	Horizontal	0.109	0.098	Yearly	10 Years
60 Gal.	Vertical	0.094	0.094	Yearly	10 Years
80 Gal.	Vertical	0.149	0.133	Yearly	10 Years
80 Gal.	Horizontal	0.109	0.133	Yearly	10 Years
120 Gal.	Vertical	0.163	0.199	Yearly	10 Years
120 Gal. & Duplex	Horizontal	0.131	0.159	Yearly	10 Years
200 Gal. Duplex	Horizontal	0.163	0.199	Yearly	10 Years

The factory recommends that all air tanks be inspected at scheduled intervals. Refer to **Recommended Air Tank Inspection Intervals Table** for relative information.

Refer to federal, state or provincial, or local codes for mandatory air tank maintenance information.

Part Callouts

Electric

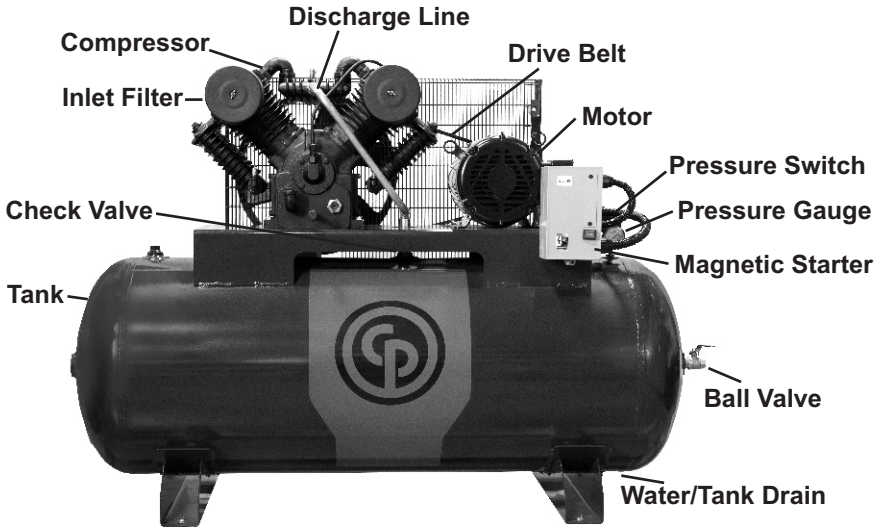

Gas Drive

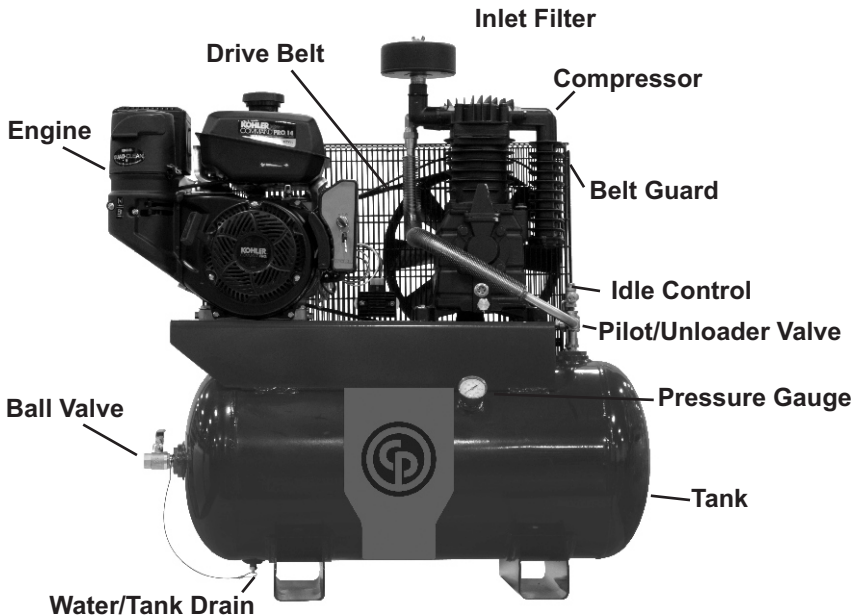

***Note: Verify Model and Part Number Before Ordering**
Change has been made to Compressor Pumps (March-April 2014)

Single Stage

*Model RCP-220P (Part# 8090254197)
 Model RCP-226VP (Part# 8090254130)
 Model RCP-3561V (Part# 8090254049)

	RCP-220P	RCP-226VP	RCP-3561V
Compressor	4116091336	4116091336	4116091337
Motor	1312100388	1312100388	1312100390
Tank	1312204900	1312205100	1312205200
Check Valve	1312100170	1312100170	1312100170
Pressure Switch	1312100455	1312100455	1312100455
Safety Valve	1312100005	1312100005	1312100005
Pressure Gauge	1312100006	1312100006	1312100840
Discharge Line	1312101048	1312101048	1312101047
Inlet Filter	2236111635	2236111635	2236111635
Water Drain	1312100360	1312100360	1312100360
BeltGuard (front)	6214343100	6214343100	6214343100
BeltGuard (back)	2236110472	2236110472	2236110472
Drive Pulley	1312100439	1312100439	1312101070
Drive Belt	1312101067	1312101067	1312100807
Unloader Line	1312100026	1312100026	1312100026
Power Cord	1312100007	1312100007	N/A
Wheel	1312100060	1312100029	N/A
Handle	2236107285	2236107294	N/A

*Model RCP-2030 (Part# 8090254247)

Contractor

*Model RCP-5530 (Part# 8090254270)
 Model RCP-6030 (Part# 8090254304)

ELECTRIC	
	RCP-2030
Compressor	4116091337
Motor	1312100388
Tank	1312203600
Check Valve	1312100168
Pressure Switch	1312100455
Safety Valve	1312100005
Pressure Gauge	1312100845
Discharge Tube	1312101156
Ball Valve	1312100161
Inlet Filter	2236111635
Tank Drain	1312100360
Unloader Line	1312100026
BeltGuard	1312101096
Drive Pulley	1312101154
Drive Belt	1312100129
Wheel	1312100461
Power Cord	1312100007

GAS DRIVE					
	RCP-5530	RCP-6030	RCP-908R	RCP-908H	RCP-128-I
Compressor	4116091337	4116091337	4116090019	4116090019	4116090019
Engine	1312100219	1312100230	1312100231	1312100221	1312100998
Tank	1312203600	1312203600	1312203300	1312203300	1312203300
Idle Control	1312100382	1312100382	1312100382	1312100382	1312100571
Unloader/Pilot Valve	1312100496	1312100496	1312100495	1312100495	1312100495
Safety Valve	1312100005	1312100005	9710533300	9710533300	9710533300
Pressure Gauge	1312100845	1312100845	1312100845	1312100845	1312100845
Discharge Tube	1312101160	1312101160	1312100204	1312100204	1312100204
Ball Valve	1312100161	1312100161	1312100161	1312100161	1312100161
Inlet Filter	2236111635	2236111635	1312100374	1312100374	1312100374
Tank Drain	1312100360	1312100360	1312100360	1312100360	1312100360
Belt Guard	1312101096	1312101096	1312101144	1312101144	1312101144
Drive Pulley	1312101070	1312101070	1312100419	1312100419	1312100419
Drive Belt	1312100131	1312100131	1312100136	1312100137	1312100136
Wheel	1312100461	1312100461	1312100461	1312100461	1312100461

Two Stage Electric

	RCP-561VNS	RCP-581VNS	RCP-381VS	RCP-381HS	RCP-338VS/4	RCP-338HS/4	RCP-581V	RCP-581H	RCP-583V/4
Pump	411609012	411609012	4116090019	4116090019	4116090019	4116090019	4116090019	4116090019	4116090019
Motor	1312101146	1312100389	1312100399	1312100399	1312101602	1312101602	1312100399	1312100399	1312101602
Tank	1312205200	1312204700	1312204700	1312203400	1312204700	1312203400	1312204700	1312203400	1312204700
Check Valve	1312100170	1312100170	1312100171	1312100171	1312100171	1312100171	1312100171	1312100171	1312100171
Pressure Switch	1312100459	1312100570	1312100570	1312100570	1312100570	1312100570	1312100570	1312100570	1312100570
Safety Valve	1310251870	9710533300	9710533300	9710533300	9710533300	9710533300	9710533300	9710533300	9710533300
Pressure Gauge	1312100840	1312100845	1312100845	1312100845	1312100845	1312100845	1312100845	1312100845	1312100845
Discharge Line	1312100214	1312100200	1312100198	1312100199	1312100198	1312100199	1312100198	1312100199	1312100198
Ball Valve	1312100162	1312100163	1312100163	1312100163	1312100163	1312100163	1312100163	1312100163	1312100163
Inlet Filter	1312100376	1312100376	1312100374	1312100374	1312100374	1312100374	1312100374	1312100374	1312100374
Tank Drain	1312100360	1312100360	1312100360	1312100360	1312100360	1312100360	1312100360	1312100360	1312100360
Belt Guard	1312101026	1312101097	1312101097	1312101097	1312101097	1312101097	1312101097	1312101097	1312101097
Drive Pulley	1312100442	1312100442	1312100422	1312100422	1312100422	1312100422	1312100422	1312100422	1312100422
Drive Belt	1312100133	1312100137	1312100140	1312100140	1312100140	1312100140	1312100140	1312100140	1312100140
Magnetic Starter (208-230V)	N/A	N/A	1312100659	1312100659	1312100654	1312100656	1312100659	1312100659	1312100656
Magnetic Starter (460V)	N/A	N/A	N/A	N/A	N/A	1312100654	N/A	N/A	1312100654
Low Oil Level Switch	N/A	N/A	N/A	N/A	N/A	N/A	1310711181	1310711181	1310711181
Auto Tank Drain	N/A	N/A	N/A	N/A	N/A	N/A	1312100110	1312100110	1312100110
	RCP-583H/4	RCP-7581VS	RCP-7581HS	RCP-7583VS/4	RCP-7583HS/4	RCP-7581V	RCP-7581H	RCP-7583V/4	RCP-7583H/4
Pump	4116090019	4116090019	4116090019	4116090019	4116090019	4116090019	4116090019	4116090019	4116090019
Motor	1312101602	1312100400	1312100400	1312101601	1312101601	1312100400	1312100400	1312101601	1312101601
Tank	1312203400	1312204700	1312203400	1312204700	1312203400	1312204700	1312203400	1312204700	1312203400
Check Valve	1312100171	1312100171	1312100171	1312100171	1312100171	1312100171	1312100171	1312100171	1312100171
Pressure Switch	1312100570	1312100570	1312100570	1312100570	1312100570	1312100570	1312100570	1312100570	1312100570
Safety Valve	9710533300	9710533300	9710533300	9710533300	9710533300	9710533300	9710533300	9710533300	9710533300
Pressure Gauge	1312100845	1312100845	1312100845	1312100845	1312100845	1312100845	1312100845	1312100845	1312100845
Discharge Line	1312100199	1312100198	1312100199	1312100198	1312100199	1312100198	1312100199	1312100198	1312100199
Ball Valve	1312100163	1312100163	1312100163	1312100163	1312100163	1312100163	1312100163	1312100163	1312100163
Inlet Filter	1312100374	1312100374	1312100374	1312100374	1312100374	1312100374	1312100374	1312100374	1312100374
Tank Drain	1312100360	1312100360	1312100360	1312100360	1312100360	1312100360	1312100360	1312100360	1312100360
Belt Guard	1312101097	1312101097	1312101097	1312101097	1312101097	1312101097	1312101097	1312101097	1312101097
Drive Pulley	1312100422	1312100420	1312100420	1312100420	1312100420	1312100420	1312100420	1312100420	1312100420
Drive Belt	1312100140	1312100139	1312100139	1312100139	1312100139	1312100139	1312100139	1312100139	1312100139
Magnetic Starter (208-230V)	1312100656	1312100662	1312100662	1312100658	1312100658	1312100662	1312100662	1312100658	1312100658
Magnetic Starter (460V)	1312100654	N/A	N/A	1312100657	1312100657	N/A	N/A	1312100657	1312100657
Low Oil Level Switch	1310711181	N/A	N/A	N/A	N/A	1310711181	1310711181	1310711181	1310711181
Auto Tank Drain	1312100110	N/A	N/A	N/A	N/A	1312100110	1312100110	1312100110	1312100110

Gas Drive and Duplex

Gas Drive

	RCP-930G	RCP-1030G	RCP-1130G	RCP-1330G	RCP-1430GK	RCP-1430G
Compressor	4116090137	4116090137	4116090019	4116090019	4116090019	4116090019
Engine	1312100232	1312100730	1312100223	1312100224	1312100998	1312100998
Tank	1312204800	1312204800	1312204800	1312204800	1312204800	1312204800
Unloader Valve	1312100497	1312100497	1312100497	1312100497	1312100497	1312100497
Safety Valve	9710533300	9710533300	9710533300	9710533300	9710533300	9710533300
Pressure Gauge	1312100845	1312100845	1312100845	1312100845	1312100845	1312100845
Discharge Line	1312100209	1312100209	1312100217	1312100217	1312100208	1312100217
Ball Valve	1312100163	1312100163	1312100163	1312100163	1312100163	1312100163
Inlet Filter	6211471600	6211471600	1312100374	1312100374	1312100374	1312100374
Tank Drain	1312100361	1312100361	1312100361	1312100361	1312100361	1312100361
Belt Guard	1312101144	1312101144	1312101144	1312101144	1312101144	1312101144
Belt	1312100136	1312100137	1312100120	1312100121	1312100120	1312100120
Unloader Line	N/A	N/A	1312100373	1312100373	N/A	N/A
Idle Control	1312100382	1312100742	1312100382	1312100382	1312100999	1312100999
Drive Pulley	1312100443	1312100443	1312100419	1312100421	1312100419	1312101044
CAST IRON						
	RCP-C1130G	RCP-C1330G	RCP-C1430G	RCP-C1630G		
Compressor	1312100706	1312100706	1312100706	1312202700		
Engine	1312100223	1312100224	1312101114	1312100731		
Tank	1312204800	1312204800	1312204800	1312101116		
Unloader Valve	1312101115	1312101115	1312101115	1312100497		
Safety Valve	9710533300	9710533300	9710533300	9710533300		
Pressure Gauge	1312100845	1312100845	1312100845	1312100845		
Discharge Line	1312101101	1312101101	1312101101	1312100720		
Ball Valve	1312100163	1312100163	1312100163	1312100162		
Inlet Filter	1312100374	1312100374	1312100374	1312100374		
Tank Drain	1312100361	1312100361	1312100361	1312100360		
Belt Guard	1312101093	1312101093	1312101093	1312204300		
Belt	1312100993	1312101138	1312101138	1312100736		
Unloader Line	1312100373	1312100373	N/A	N/A		
Idle Control	1312101049	1312101049	1312100099	1312100741		
Drive Pulley	1312100711	1312101040	1312101040	1312100711		

Duplex

	RCP-10121D	RCP-10123D	RCP-10123D4	RCP-15121D	RCP-15123D	RCP-15123D4
Compressor	4116090019	4116090019	4116090019	4116090019	4116090019	4116090019
Motor	1312100399	1312101602	1312101602	1312100400	1312101601	1312101601
Tank	1312203500	1312203500	1312203500	1312203500	1312203500	1312203500
Check Valve	1312100171	1312100171	1312100171	1312100171	1312100171	1312100171
Pressure Switch	1312100570	1312100570	1312100570	1312100570	1312100570	1312100570
Safety Valve	9710533300	9710533300	9710533300	9710533300	9710533300	9710533300
Pressure Gauge	1312100845	1312100845	1312100845	1312100845	1312100845	1312100845
Discharge Line	1312100212 (R) 1312100211 (L)	1312100212 (R) 1312100211 (L)	1312100212 (R) 1312100211 (L)	1312100212 (R) 1312100211 (L)	1312100212 (R) 1312100211 (L)	1312100212 (R) 1312100211 (L)
Ball Valve	1312100163	1312100163	1312100163	1312100163	1312100163	1312100163
Inlet Filter	1312100374	1312100374	1312100374	1312100374	1312100374	1312100374
Filter Element	FE001	FE001	FE001	FE001	FE001	FE001
Tank Drain	1312100360	1312100360	1312100360	1312100360	1312100360	1312100360
Belt Guard	1312101144 (R) 1312101097 (L)	1312101144 (R) 1312101097 (L)	1312101144 (R) 1312101097 (L)	1312101144 (R) 1312101097 (L)	1312101144 (R) 1312101097 (L)	1312101144 (R) 1312101097 (L)
Drive Belt	1312100140	1312100140	1312100140	1312100139	1312100139	1312100139
Drive Pulley	1312100422	1312100422	1312100422	1312100420	1312100420	1312100420
Unloader Line	1312100373	1312100373	1312100373	1312100373	1312100373	1312100373
Panel Assembly	1312207500	1312207500	1312207600	1312207500	1312207500	1312207600
Magnetic Starter	1312101187	1312101187	1312101192	1312101187	1312101187	1312101192
Controller	1312101185	1312101185	1312101185	1312101185	1312101185	1312101185

RCP QP

	RCP-581VQP	RCP-583VQP	RCP-7581VQP	RCP-7583VQP
Compressor	4116090019	4116090019	4116090019	4116090019
Motor	1312100399	1312100602	1312100400	1312101601
Tank	1312204700	1312204700	1312204700	1312204700
Check Valve	1312100171	1312100171	1312100171	1312100171
Pressure Switch	1312100570	1312100570	1312100570	1312100570
Safety Valve	9710533300	9710533300	9710533300	9710533300
Pressure Gauge	1312100845	1312100845	1312100845	1312100845
Mag. Starter	1312100659	1312100656	1312100662	1312100658
Canopy	1312202180	1312202180	1312202180	1312202180
Tank Drain	1312100110	1312100110	1312100110	1312100110
Ball Valve	1312100163	1312100163	1312100163	1312100163
Discharge Line	1312100198	1312100198	1312100198	1312100198
Inlet Filter	1312100097	1312100097	1312100097	1312100097
Low Oil Switch	1310711181	1310711181	1310711181	1310711181
Blower	1312100088	1312100088	1312100088	1312100088
Belt Guard	1312101097	1312101097	1312101097	1312101097
Belt	1312100140	1312100140	1312100139	1312100139
Unloader Line	1312100373	1312100373	1312100373	1312100373
Drive Pulley	1312100422	1312100422	1312100420	1312100420
High Temp Switch	1312100089	1312100089	1312100089	1312100089

RCP-C (Iron Series)

Two Stage Electric (RCP-C)

STANDARD								
	RCP-C581VS	RCP-C583VS (4)	RCP-C7581VS	RCP-C7583VS (4)	RCP-C7581VSC2	RCP-C7583VSC2 (4)	RCP-C10123VS (4)	RCP-C10123HS (4)
Compressor	1312100706	1312100706	1312100706	1312100706	1312202700	1312202700	1312202700	1312202700
Motor	1312100399	1312101602	1312100400	1312101601	1312100394	1312101601	1312101600	1312101600
Belt Guard	1312100982	1312100982	1312100982	1312100982	1312100982	1312204400	1312100983	1312100983
Discharge Line	1312100994	1312100994	1312100994	1312100994	1312100717	1312100717	1312100717	1312100717
Pressure Switch	1312100570	1312100570	1312100570	1312100570	1312100570	1312100570	1312100570	1312100570
Ball Valve	1312100163	1312100163	1312100163	1312100163	1312100163	1312100163	1312100570	1312100570
Unloader Line	1312100026	1312100026	1312100026	1312100026	1312100026	1312100026	1312100026	1312100026
Safety Valve	9710533300	9710533300	9710533300	9710533300	9710533300	9710533300	9710533300	9710533300
Pressure Gauge	1312100845	1312100845	1312100845	1312100845	1312100845	1312100845	1312100845	1312100845
Tank	1312204700	1312204700	1312204700	1312204700	1312101251	1312101251	1312203800	1312203800
Tank Drain	1312100360	1312100360	1312100360	1312100360	1312100360	1312100360	1312100360	1312100360
Magnetic Starter 230V	1312100659	1312100659	1312100662	1312100659	1312100662	1312100662	1312100661	1312100661
Magnetic Starter 460V	N/A	1312100654	N/A	1312100657	N/A	1312100657	1312100657	1312100657
Drive Pulley	1312100714	1312100714	1312100938	1312100938	1312100712	1312100712	1312100713	1312100713
Bushing	1312100445	1312100445	1312100445	1312100445	1312100446	1312100446	1312100446	1312100446
Belt	1312100993	1312100993	1312100939	1312100939	1312100722	1312100722	1312100736	1312100736
Check Valve	1312100171	1312100171	1312100171	1312100171	1312100172	1312100172	1312100172	1312100172
PREMIUM								
	RCP-C581V	RCP-C583V (4)	RCP-C7581V	RCP-C7583V (4)	RCP-C7581V2	RCP-C7583V2 (4)	RCP-C10123V (4)	RCP-C10123H (4)
Compressor	1312100706	1312100706	1312100706	1312100706	1312202700	1312202700	1312202700	1312202700
Motor	1312100399	1312101602	1312100400	1312101601	1312100394	1312101601	1312101600	1312101600
Belt Guard	1312100982	1312100982	1312100982	1312100982	1312204400	1312204400	1312100983	1312100983
Discharge Line (Top)	1312101101	1312101101	1312101101	1312101101	1312101102	1312101102	1312101102	1312101101
Discharge Line (Btm)	1312101102	1312101102	1312101102	1312101102	1312101102	1312101102	1312101102	1312101102
Pressure Switch	1312100570	1312100570	1312100570	1312100570	1312100570	1312100570	1312100570	1312100570
Ball Valve	1312100163	1312100163	1312100163	1312100163	1312100163	1312100163	1312100163	1312100163
Unloader Line	1312100026	1312100026	1312100026	1312100026	1312100026	1312100026	1312100026	1312100026
Safety Valve	9710533300	9710533300	9710533300	9710533300	9710533300	9710533300	9710533300	9710533300
Pressure Gauge	1312100845	1312100845	1312100845	1312100845	1312100845	1312100845	1312100845	1312100845
Tank	1312204700	1312204700	1312204700	1312204700	1312101251	1312101251	1312203800	1312203800
Tank Drain	1312100110	1312100110	1312100110	1312100110	1312100360	1312100360	1312100110	1312100110
Magnetic Starter 230V	1312100659	1312100656	1312100662	1312100658	1312100662	1312100662	1312100661	1312100661
Magnetic Starter 460V	N/A	1312100654	N/A	1312100657	N/A	1312100657	1312100657	1312100657
Drive Pulley	1312100714	1312100714	1312100938	1312100938	1312100712	1312100712	1312100713	1312100713
Bushing	1312100445	1312100445	1312100445	1312100445	1312100446	1312100446	1312100446	1312100446
Belt	1312100993	1312100993	1312100939	1312100939	1312100722	1312100722	1312100736	1312100736
Check Valve	1312100167	1312100167	1312100167	1312100167	1312100167	1312100167	1312100167	1312100172
Aftercooler	1312100611	1312100611	1312100611	1312100611	1312100611	1312100611	1312100611	1312100611
Low Oil Switch	1312101285	1312101285	1312101285	1312101285	1312101285	1312101285	1312101285	1312101285
LOS - Housing	1312101232	1312101232	1312101232	1312101232	1312101232	1312101232	1312101232	1312101232

Duplex (RCP-C)

	RCP-C10121D	RCP-C10123D	RCP-C10123D4	RCP-C15121D	RCP-C15123D	RCP-C15123D4	RCP-C20123D	RCP-C20123D4	RCP20203D	RCP20203D4
Compressor	1312202800	1312202800	1312202800	1312202800	1312202800	1312202800	1312202700	1312202700	1312202700	1312202700
Motor	1312100399	1312101602	1312101602	1312100400	1312101601	1312101601	1312101600	1312101600	1312101600	1312101600
Belt Guard	1312204300 (R)	1312204300 (R)	1312204300 (R)	1312204300 (R)	1312204300 (R)	1312204300 (R)	1312204300 (R)	1312204300 (R)	1312204300 (R)	1312204300 (R)
	1312204400 (L)	1312204400 (L)	1312204400 (L)	1312204400 (L)	1312204400 (L)	1312204400 (L)	1312204400 (L)	1312204400 (L)	1312204400 (L)	1312204400 (L)
Discharge Line	1312100716 (R)	1312100716 (R)	1312100716 (R)	1312100716 (R)	1312100716 (R)	1312100716 (R)	1312100717 (R)	1312100717 (R)	1312100717 (R)	1312100717 (R)
	1312100719 (L)	1312100719 (L)	1312100719 (L)	1312100719 (L)	1312100719 (L)	1312100719 (L)	1312100717 (L)	1312100717 (L)	1312100717 (L)	1312100717 (L)
Ball Valve	1312100163	1312100163	1312100163	1312100163	1312100163	1312100163	1312100163	1312100163	1312100163	1312100163
Pressure Switch	1312100570	1312100570	1312100570	1312100570	1312100570	1312100570	1312100570	1312100570	1312100570	1312100570
Unloader Line	1312100026	1312100026	1312100026	1312100026	1312100026	1312100026	1312100026	1312100026	1312100026	1312100026
Safety Valve	9710533300	9710533300	9710533300	9710533300	9710533300	9710533300	9710533300	9710533300	9710533300	9710533300
Pressure Gauge	1312100840	1312100840	1312100840	1312100840	1312100840	1312100840	1312100840	1312100840	1312100840	1312100840
Tank	1312208202	1312208202	1312208202	1312208202	1312208202	1312208202	1312208202	1312208202	1312208202	1312208202
Tank Drain	1312100360	1312100360	1312100360	1312100360	1312100360	1312100360	1312100360	1312100360	1312100360	1312100360
Drive Pulley	1312100714	1312100714	1312100714	1312100938	1312100938	1312100938	1312100713	1312100713	1312100713	1312100713
Bushing	1312100445	1312100445	1312100445	1312100445	1312100445	1312100445	1312100446	1312100446	1312100446	1312100446
Belt	1312100724	1312100724	1312100724	1312100721	1312100721	1312100721	1312100723	1312100723	1312100723	1312100723
Check Valve	1312100171	1312100171	1312100171	1312100171	1312100171	1312100171	1312100172	1312100172	1312100172	1312100172
Panel Assembly	1312207500	1312207500	1312207500	1312207500	1312207500	1312207500	1312207500	1312207500	1312207500	1312207500
Magnetic Starter	1312101187	1312101187	1312101192	1312101187	1312101187	1312101192	1312101187	1312101192	1312101187	1312101192
Controller	1312101185	1312101185	1312101185	1312101185	1312101185	1312101185	1312101185	1312101185	1312101185	1312101185

Compressor Pump 4116091336 (PAT24) and 4116091337 (PAT38)

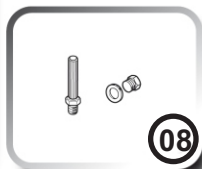
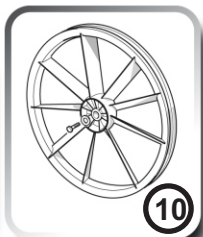
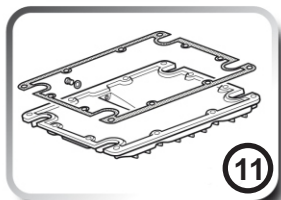
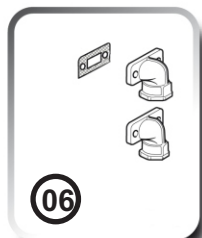
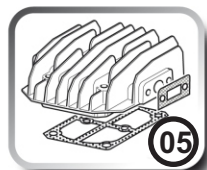
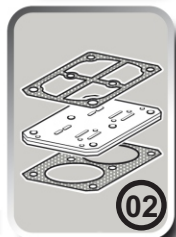
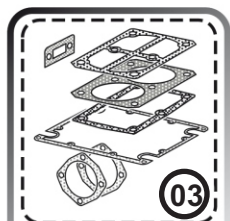
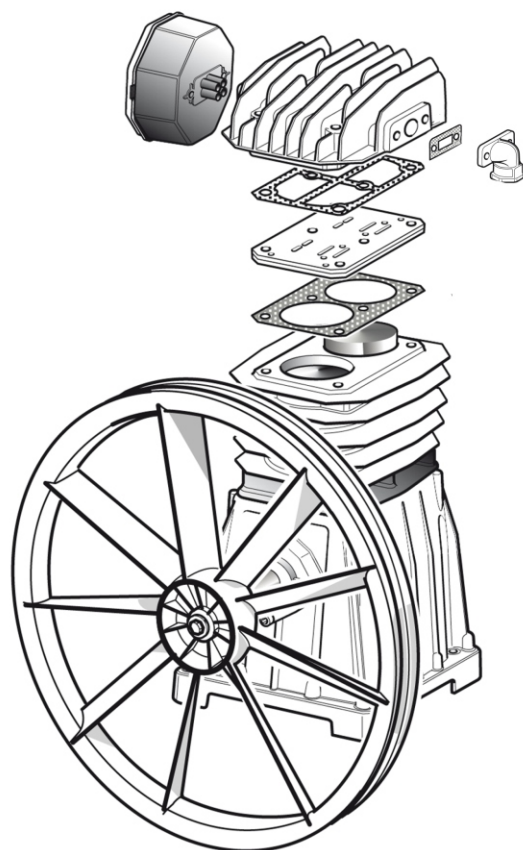

Compressor Pump 4116091336 (PAT24) and 4116091337 (PAT38)

01	Air Filter Kit	2236111635
02	Valve Assembly Kit	2236112518
03	Gasket Kit	2901325045
04	Bearing and Ring Kit	2901325046
05	Head Kit	2901325044
06	Discharge Elbow Kit	2901325047
07	Cylinder Kit	2236112434(PAT24) 2236112435(PAT38)
08	Oil Level Kit	6229021000
09	Conrod Kit	2236111619(PAT24) 2236111620(PAT38)
10	Flywheel Kit	6229023400(PAT24) 2901325048(PAT38)
11	Crankcase Bottom Kit	2236112437(PAT24) 2236112438(PAT38)

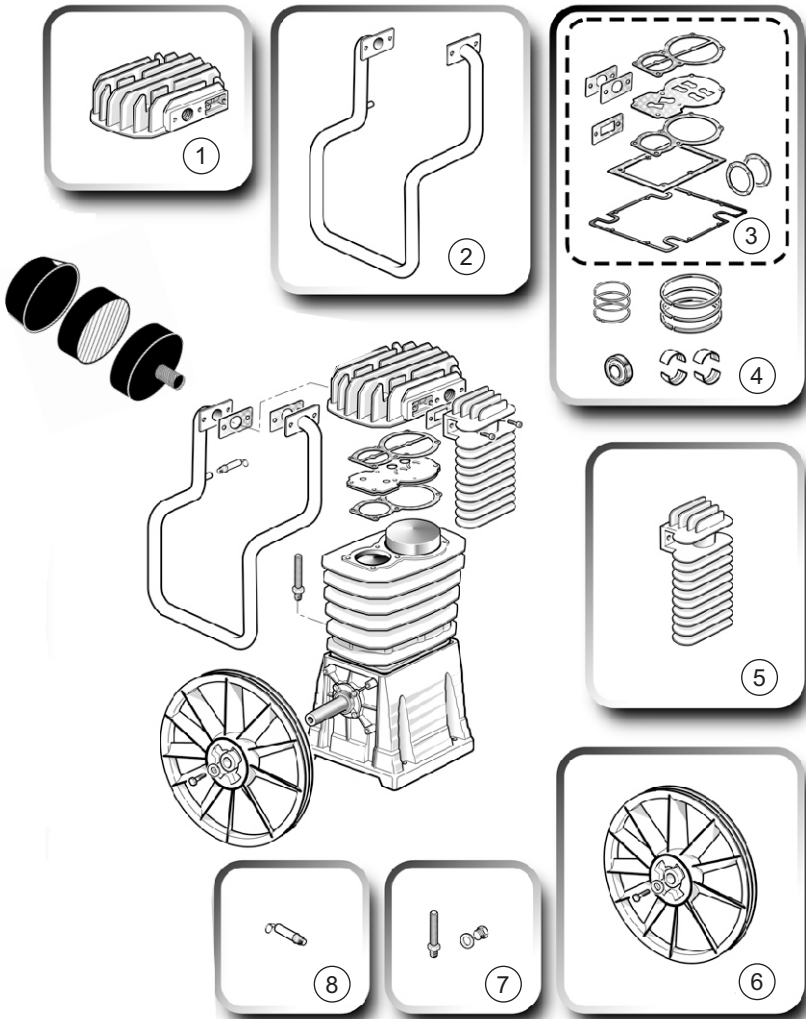

Ill. No.	Part Number	Description
1	2901324960	Head Kit
2	2901324961	Intercooler Kit
3	8973035118	Gasket Kit
4	6229017300	Overhaul Kit
5	2901324962	Aftercooler Kit
6	6229017600	Flywheel Kit
7	2901324950	Oil Level Kit
8	2901324963	65 psi Safety Valve
	1312100376	Filter Assembly
	FE004	Filter Element
	2236102992	Oil Sight Glass
	6211848600	Flywheel Bolt
	6214242800	Flywheel Washer
	6210717280	Valve Assembly

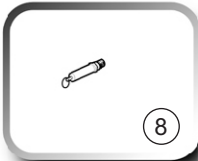
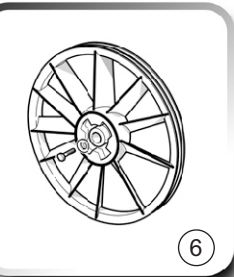
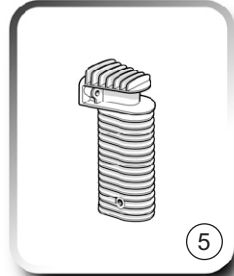
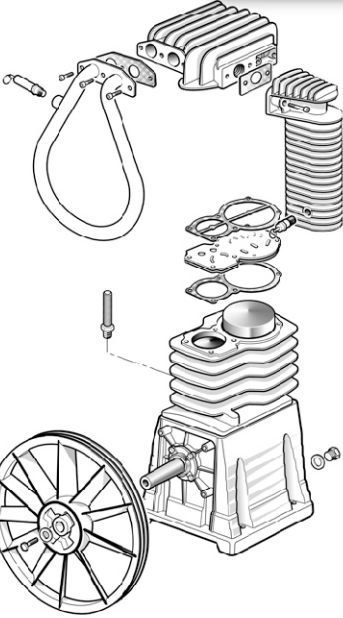
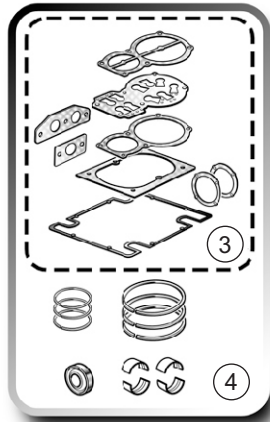
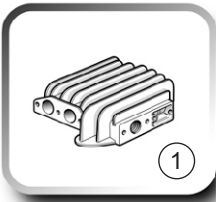

Ill. No.	Part Number	Description
1	2901324964	Head Kit
2	2901324965	Intercooler Kit
3	8973037264	Gasket Kit
4	6229026900	Overhaul Kit
5	2901324966	Aftercooler Kit
6	6229020100	Flywheel Kit
7	2901324951	Oil Level Kit
8	2901324963	65 psi Safety Valve
	2901324974	217 psi Safety Valve
	6211471600	Filter Assembly
	8973035122	Filter Element
	6214341200	Oil Sight Glass
	6211848500	Flywheel Bolt
	6214242700	Flywheel Washer
	6210716900	Valve Assembly

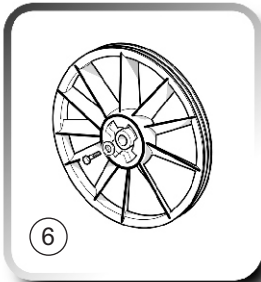
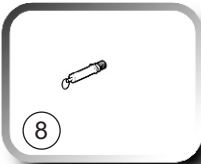
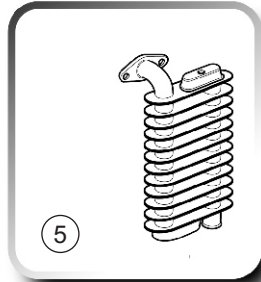
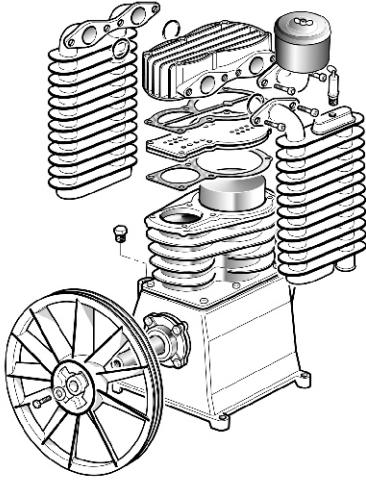
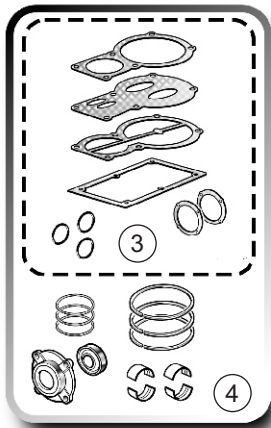
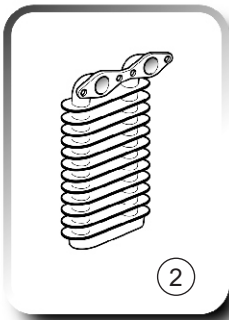
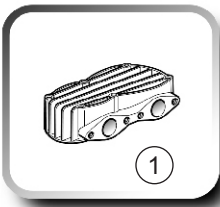

Ill. No.	Part Number	Description
1	2901324971	Head Kit
2	2901324972	Intercooler Kit
3	1310711137	Gasket Kit
4	1310711168	Overhaul Kit
5	2901324973	Aftercooler Kit
6	6229018800	Flywheel Kit
7	2901324954	Oil Level Kit
8	1312100456	225 psi Safety Valve
	1312100374*	Filter Assembly
	FE001*	Filter Element
	2236102992	Oil Sight Glass
	6211848500	Flywheel Bolt
	6214242700	Flywheel Washer
	2901324723	Valve Kit
*QP Models	1312100097	Filter Assembly
	FE004	Filter Element

T39
(4116090019)

C1 (1312202800)

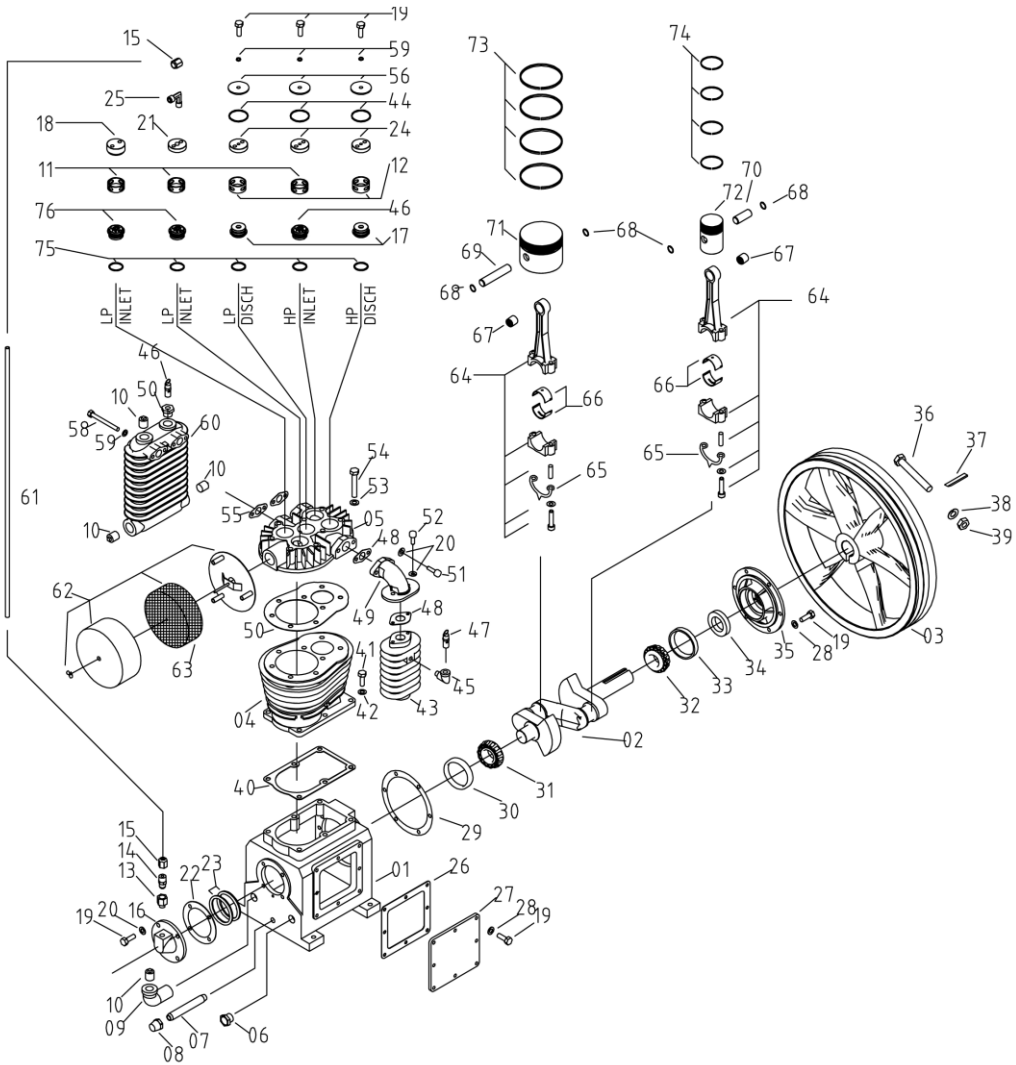

C1

(1312202800)

Item	Description	Qty	Part #
1	Crankcase	1	1312100876
2	Crank Shaft	1	1312100932
3	Fly Wheel	1	1312100884
4	Cylinder	1	1312100880
5	Head	1	1312100878
6	Oil Sight Glass	1	1312100903
7	Oil Drain Pipe	1	1312100859
8	Oil Drain Pipe Cap	1	1312100861
9	Oil Fill Elbow	1	1312100933
10	Plug	4	1312100866
11	Spacer - Inlet Valve	2	1312100893
12	Spacer Discharge Valve	3	1312100894
13	Breather Body	1	1312100934
14	Copper Connector	1	1312100860
15	Copper Nut	2	1312100856
16	Cover-Centrifugal Unloader	1	1312100899
17	Valve Assy HP/LP Discharge	2	1312100892
18	Retainer Inlet Valve	1	1312100898
19	Capscrew-Hex M8x25	21	0147132503
20	Lockwasher 8	8	0333222500
21	Retainer Inlet Valve	1	1312100895
22	Gasket Rear Cap	1	1312100920
23.1	Shim 0.20 Brg. Adj.	1	1312100930
23.2	Shim 0.10 Brg. Adj.	2	1312100929
24	Retainer Discharge Valve	3	1312100896
25	Copper Elbow	1	1312100857
26	Gasket Side Cover	1	1312100916
27	Cover Crankcase Side	1	1312100858
28	Copper Gasket	14	1312100921
29	Gasket Front Cap	1	1312100915
30	Bearing Cap Rear	1	1312100909
31	Bearing Cone Rear	1	1312100908
32	Bearing Cone Front	1	1312100906
33	Bearing Cap Front	1	1312100907
34	Seal-Shaft	1	1312100911
35	Cap Front	1	1312100868
36	Capscrew-Hex M16x120	1	0147149203
37	Key Fly Wheel C1	1	1312100928
38	Lockwasher 16	1	0333224300
39	Nut - Hex M16	1	0261111403
40	Gasket - Cylinder to Crankcase	1	1312100914

41	Capscrew-Hex M10x30	6	0147136303
42	Copper Gasket 10	6	1312100923
43	Aftercooler	1	1312100875
44	Gasket Valve Cover	3	1312100919
45	Elbow - Street	2	1312100865
46	Valve Assy HP Inlet	1	1312100891
47	Safety Valve 250 psi	1	1312100862
48	Gasket Aftercooler	2	1312100918
49	Elbow Aftercooler	1	1312100873
50	Gasket - Cylinder Head	1	1312100913
51	Capscrew - Skt HD M8x30	2	0211132603
52	Capscrew - Skt HD M8x25	2	0211132503
53	Lockwasher 12	8	0333223600
54	Capscrew-Hex M12x70	8	0147140903
55	Gasket Intercooler	2	1312100927
56	Cover Valve	3	1312100897
57	Safety Valve 75 psi	1	1312100889
58	Capscrew-Hex M8x90	4	0147133803
59	Copper Gasket B8	7	1312100924
60	Intercooler	1	1312100871
61	Aluminum Tube 10x380	1	1312100863
62	Filter Inlet Assembly	1	1312100881
63	Filter Replacement Element	1	FE001
64	Connecting Rod	2	1312100869
65	Dipper-Oil	2	1312100870
66	Insert Half	4	1312100905
67	Bearing- Wrist Pin Needle	2	1312100910
68	Snap Ring - Internal	4	1312100867
69	Wrist Pin LP Piston	1	1312100901
70	Wrist Pin HP Piston	1	1312100902
71	Piston-LP	1	1312100887
72	Piston-HP	1	1312100888
73	Piston Ring Set- LP	1	1312100885
74	Piston Ring Set- HP	1	1312100886
75	Copper Gasket - Valve Seat	5	1312100922
76	Valve Assembly-LP Inlet	2	1312100890
77	Bushing 3/4 x 1 1/4"	1	1312100334
	Gasket Set		1312100925
	Head Rebuild Kit		1312100780
	Overhaul Kit		1312100775

C2 (1312202700)

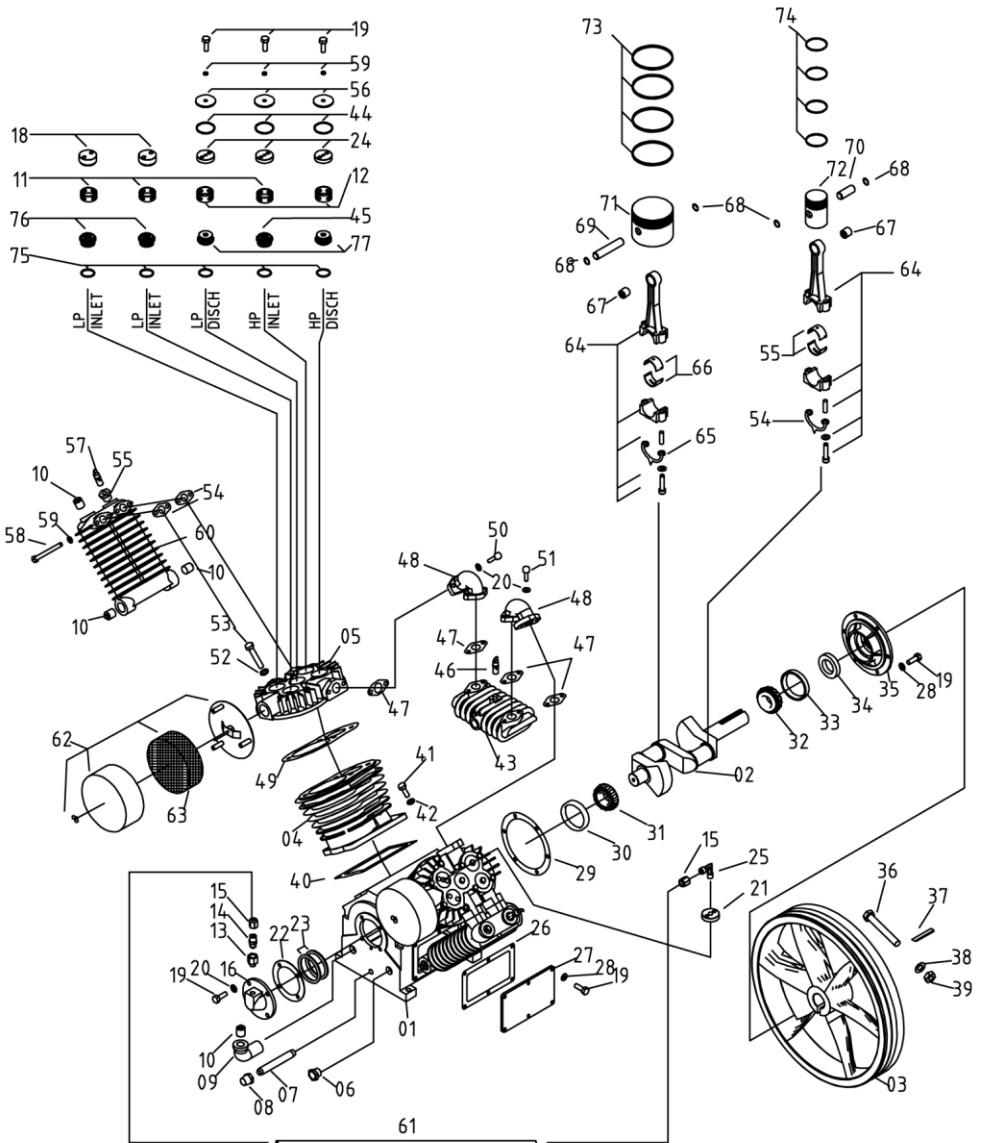

C2

(1312202700)

Item	Description	Qty	Part #
1	Crankcase	1	1312100877
2	Crank Shaft	1	1312100931
3	Fly Wheel	1	1312100883
4	Cylinder	1	1312100880
5	Head (Left)	1	1312100878
	Head (Right)	1	1312100879
6	Oil Sight Glass	1	1312100903
7	Oil Drain Pipe	1	1312100859
8	Oil Drain Pipe Cap	1	1312100861
9	Oil Fill Elbow	1	1312100933
10	Plug	4	1312100866
11	Spacer - Inlet Valve	2	1312100893
12	Spacer Discharge Valve	3	1312100894
13	Breather Body	1	1312100934
14	Copper Connector	1	1312100860
15	Copper Nut	2	1312100856
16	Cover-Centrifugal Unloader	1	1312100899
18	Retainer Inlet Valve	4	1312100898
19	Capscrew-Hex M8x25	28	0147132503
20	Lockwasher 8	8	0333222500
21	Retainer Inlet Valve	2	1312100895
22	Gasket Rear Cap	1	1312100920
23.1	Shim 0.20 Brg. Adj.	1	1312100930
23.2	Shim 0.10 Brg. Adj.	2	1312100929
24	Retainer Discharge Valve	4	1312100896
25	Copper Elbow	1	1312100857
26	Gasket Side Cover	2	1312100917
27	Cover Crankcase Side	2	1312100904
28	Copper Gasket	26	1312100921
29	Gasket Front Cap	1	1312100915
30	Bearing Cap Rear	1	1312100909
31	Bearing Cone Rear	1	1312100908
32	Bearing Cone Front	1	1312100906
33	Bearing Cap Front	1	1312100907
34	Seal-Shaft	1	1312100911
35	Cap Front	1	1312100868
36	Capscrew-Hex M16x120	1	0147149203
37	Key Fly Wheel C1	1	1312100928
38	Lockwasher 16	1	0333224300
39	Nut - Hex M16	1	0261111403
40	Gasket - Cylinder to Crankcase	1	1312100914
41	Capscrew-Hex M10x30	12	0147136303
42	Copper Gasket 10	12	1312100923

43	Aftercooler	1	1312100874
44	Gasket Valve Cover	6	1312100919
45	Valve Assy HP Inlet	2	1312100891
46	Safety Valve 250 psi	1	1312100862
47	Gasket Aftercooler	4	1312100918
48	Elbow Aftercooler	2	1312100872
49	Gasket - Cylinder Head	2	1312100913
50	Capscrew - Skt HD M8x30	4	0211132603
51	Capscrew - Skt HD M8x25	4	0211132503
52	Lockwasher 12	16	0333223600
53	Capscrew-Hex M12x70	16	0147140903
54	Gasket Intercooler	4	1312100927
55	Reducing Bushing	2	1312100864
56	Cover Valve	6	1312100897
57	Safety Valve 75 psi	2	1312100889
58	Capscrew-Hex M8x90	8	0147140903
59	Copper Gasket B8	14	1312100924
60	Intercooler	2	1312100871
61	Aluminum Tube 10x380	1	1312100863
62	Filter Inlet Assembly	2	1312100881
63	Filter Replacement Element	2	FE001
64	Connecting Rod	4	1312100869
65	Dipper-Oil	4	1312100870
66	Insert Half	8	1312100905
67	Bearing- Wrist Pin Needle	4	1312100910
68	Snap Ring - Internal	8	1312100867
69	Wrist Pin LP Piston	2	1312100901
70	Wrist Pin HP Piston	2	1312100902
71	Piston-LP	2	1312100887
72	Piston-HP	2	1312100888
73	Piston Ring Set- LP	2	1312100885
74	Piston Ring Set- HP	2	1312100886
75	Copper Gasket - Valve Seat	10	1312100922
76	Valve Assembly-LP Inlet	4	1312100890
77	Valve Assembly HP/LP	4	1312100334
	Gasket Set	1	1312100926
	Head Rebuild Kit		1312100781
	Overhaul Kit		1312100776

Warranty Statement

The Company warrants that the Equipment manufactured by it and delivered hereunder shall be free from defects in material and workmanship for a period of twelve (12) months from the date of initial start-up, or eighteen (18) months from the date of shipment from the manufacturer, whichever occurs first. The foregoing warranty period shall apply to all Equipment, except for the following: (A) all two stage reciprocating stationary models are warranted for the earlier of twenty-four (24) months from the date of initial operation or thirty (30) months from date of shipment from the manufacturer. (B) Replacement parts will be warranted for three (3) months from the date of shipment from the manufacturer. Should the failure to conform to this warranty be reported in writing to the Company within said period, the Company shall, at its option, correct such non-conformity by suitable repair to such Equipment, or furnish a replacement part F.O.B point of shipment, provided that the Purchaser has installed, maintained, and operated such Equipment in accordance with good industry practices, and has complied with specific recommendations of the Company. Accessories and equipment furnished by the Company, but manufactured by others, shall carry whatever warranty the manufacturer conveyed to the Company and which can be passed on to the Purchaser. The Company shall not be liable for any repairs, replacements, or adjustments to the Equipment, or any costs of labor performed by the Purchaser without the Company's prior written approval.

The Company makes no performance warranty unless specifically stated within its proposal, and the effects of corrosion, erosion, and normal wear and tear are specifically excluded from the Company's warranty. In the event performance warranties are expressly included, the Company's obligation shall be to correct in the manner and for the period of time provided above.

THE COMPANY MAKES NO OTHER WARRANTY OR REPRESENTATION OF ANY KIND WHATSOEVER, EXPRESSED OR IMPLIED, EXCEPT THAT OF TITLE, AND ALL IMPLIED WARRANTIES OF MERCHANTABILITY AND FITNESS FOR A PARTICULAR PURPOSE, ARE HEREBY DISCLAIMED. THIS WARRANTY SUPERSEDES ALL PREVIOUS WARRANTY STATEMENTS.

Correction by the Company of non-conformities, whether patent or latent, in the manner and for the period of time provided above, shall constitute fulfillment of all liabilities of the Company and its distributors for such non-conformities with respect to, or arising out of such Equipment.

LIMITATION OF LIABILITY

THE REMEDIES OF THE PURCHASER SET FORTH HEREIN ARE EXCLUSIVE, AND THE TOTAL LIABILITY OF THE COMPANY, ITS DISTRIBUTORS AND SUPPLIERS WITH RESPECT TO CONTRACT OR THE EQUIPMENT AND SERVICES FURNISHED IN CONNECTION WITH THE PERFORMANCE OR BREACH THEREOF, OR FROM THE MANUFACTURE, SALE, DELIVERY, INSTALLATION, REPAIR OR TECHNICAL DIRECTION COVERED OR FURNISHED UNDER CONTRACT, WHETHER BASED ON CONTRACT, WARRANTY, NEGLIGENCE, INDEMNITY, STRICT LIABILITY OR OTHERWISE, SHALL NOT EXCEED THE PURCHASE PRICE OF THE EQUIPMENT UPON WHICH SUCH LIABILITY IS BASED.

THE COMPANY, ITS DISTRIBUTORS AND ITS SUPPLIERS SHALL IN NO EVENT BE LIABLE TO THE PURCHASER, ANY SUCCESSORS IN INTEREST, OR ANY BENEFICIARY OR ASSIGNEE OF THE CONTRACT FOR ANY CONSEQUENTIAL, INCIDENTAL, INDIRECT, SPECIAL OR PUNITIVE DAMAGES ARISING OUT OF THIS CONTRACT OR ANY BREACH THEREOF, OR ANY DEFECT IN, OR FAILURE OF, OR MALFUNCTION OF THE EQUIPMENT, WHETHER OR NOT BASED ON LOSS OF USE, LOST PROFITS OR REVENUE, INTEREST, LOST GOODWILL, WORK STOPPAGE, IMPAIRMENT OF OTHER GOODS, LOSS BY REASON OF SHUTDOWN OR NON-OPERATION, COST OF PURCHASE OF REPLACEMENT POWER, OR CLAIMS OF PURCHASER OR CUSTOMERS OF PURCHASER FOR SERVICE INTERRUPTION, WHETHER OR NOT SUCH LOSS OR DAMAGE IS BASED ON CONTRACT, WARRANTY, NEGLIGENCE, INDEMNITY, STRICT LIABILITY OR OTHERWISE.

Chicago Pneumatic Compressors
1800 Overview Drive
Rock Hill, SC 29730
866-869-3114 (Parts and Technical)